

# DIMENSIONI D'INGOMBRO

## DIMENSIONS

01 PLP 05 16 FHRM

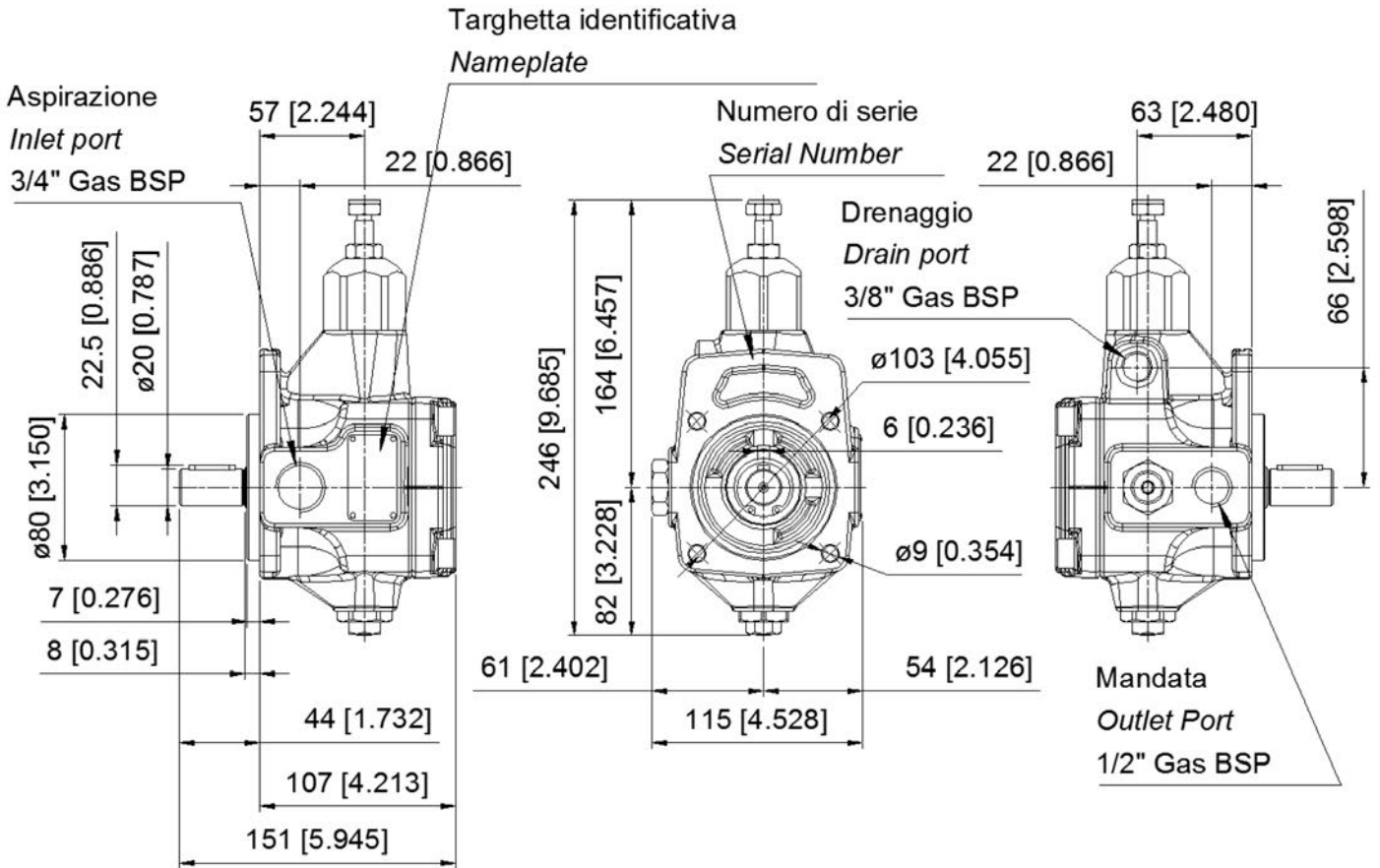

Dimensioni fra [ ] sono in pollici

Dimensions inside [ ] are in inches

### VERSIONE CON ALBERO PASSANTE (-A) THRU-DRIVE SHAFT (-A)

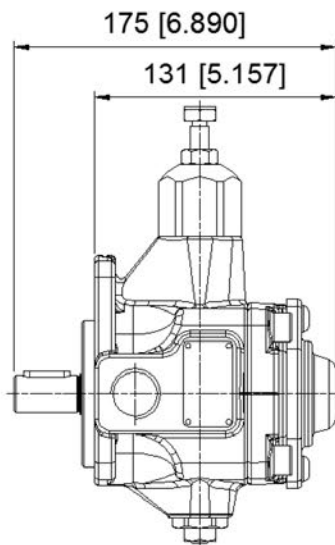

**NOTA:** Disponibile solo con flangia tipo F  
**NOTE:** Available only with F flange

Per l'opzione pompe combinate vedere pagine 9÷11  
For combined pump solutions, please see pages 9÷11

Dimensioni fra [ ] sono in pollici

Dimensions inside [ ] are in inches

### FLANGIA ED ALBERO FGR2 FLANGE AND SHAFT FGR2

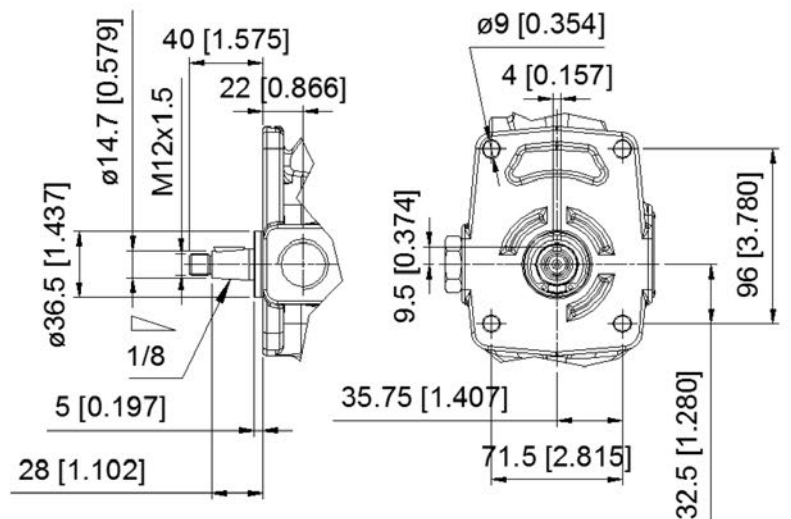

Dimensioni fra [ ] sono in pollici

Dimensions inside [ ] are in inches